

**ROTATING RIGHT**

# COMPLETE HOUSED & PIPED PACKAGES

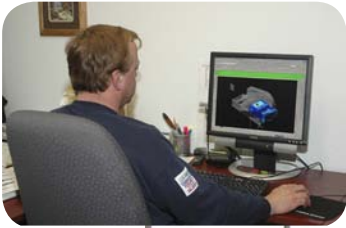

# Complete Housed & Piped Packages

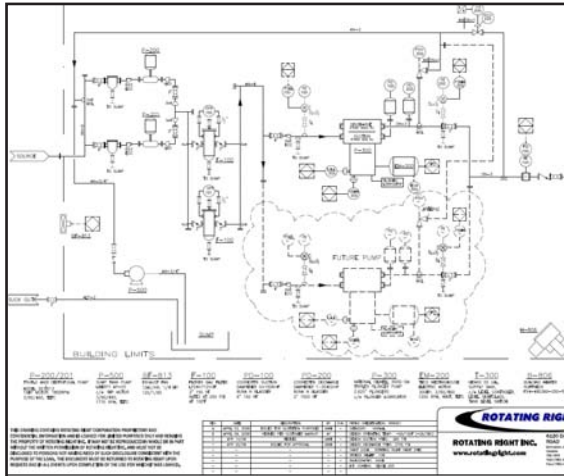
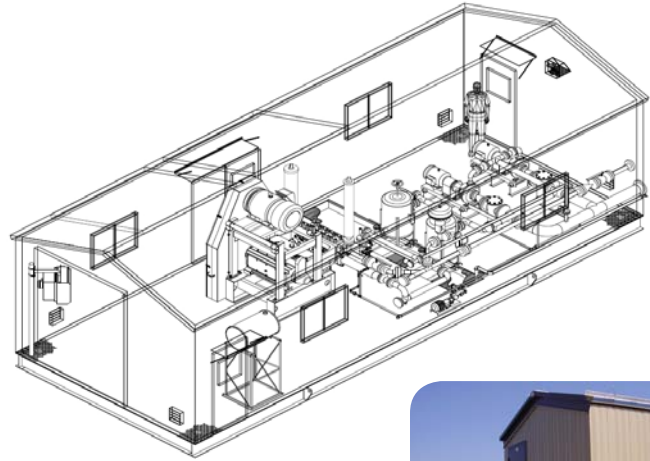

## Fabricated Systems

Rotating Right specializes in fabricated turn key housed and piped packages. Our growing product distribution allows us to manufacture virtually any type of pumping system whether it be a simple pump skid or a complete pump package including controls, accessories and building designed to your specifications.

Our experienced engineering staff includes drafting, engineering and applications personnel available to discuss your pumping needs and assist in designing a system that is right for you.

Our fabrication group includes "B" pressure certified welders and journeymen fabricators and fitters. All our packages are backed by our "Fabricated Systems Guarantee" and our factory trained service personnel ready to assist with installation and start-up of your next system.



## *Features*

- Quality Assurance Program
- Experienced Engineering & Applications Personnel
- "B" Certified Welders
- Expert Fabricators & Fitters
- B31.1 Certification
- 3D Animation
- CAD Drawings
- P&ID's
- Finite Element Analysis
- System Specifications
- Built For H2S Environments
- System Guarantee
- Service & Start-up Assistance

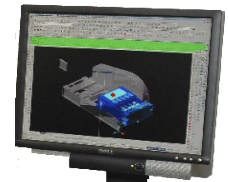

# Pump Packages With Buildings

## Experience

Drawing upon our resources and experience, we have the ability to fabricate a full range of mechanical and process packages, from stand alone pump skids to modular subassemblies and fully-functional equipment skids.

### Fabrication Policies

- Superior quality control procedures
- A “manufacturing” approach to fabrication
- Standardized fabrication procedures
- An environment optimized for production
- Efficient material storage and control
- Accurate productivity measures
- A culture of continuous improvement

AN INDUSTRY LEADER IN THE FABRICATION OF  
QUALITY PUMP PACKAGES & TURNKEY  
SYSTEMS



# Unitized Skid Package

## Design Innovation

One factor that sets us apart from other companies is our design and fabrication capability. Our technical representatives, engineers and fabricators are constantly designing and building custom equipment for use in the field.

Rotating Right offers the technical know how to assist in the design of your system and the resources to see your fabrication project through to installation and commissioning.

All of this translates to a superior finished product delivered to you, at a better bottom line.

These few examples are only an illustration of some of our design and fabrication capabilities.

If you have a unique or complex process problem that requires an innovative solution, call us. We have the personnel, the expertise, and the equipment to handle the most challenging projects.



# Simple Centrifugal Pump Package

## ANSI Pump, Motor, Base packages

Griswold's line of 811 ANSI Pumps are engineered for flexibility and durability. The 811 is available in a wide range of sizes, capacities and materials to fit virtually any process fluid application. With over 30 selections and multiple design options, we've got your application covered—for abrasive and corrosive substances, and capacities ranging from 4 through 4000 gallons per minute.

Griswold maintains strict quality assurance programs to ensure that the entire product line is manufactured to the highest standard for engineered tolerances.

Challenge your existing equipment quality, delivery and costs with our ready-to-ship inventory of 811 pumps and parts. Our 811 pump line and wearing parts interchange quickly and seamlessly with a variety of ANSI pump models and brands – without piping, baseplate or coupling changes... All at a significant cost savings!

Whether you need a complete pumping system or a simple pump skid package we have the capabilities to offer fast turn around times at a competitive price designed to your specifications.



# Multiphase Package With Building

## • Design • Innovation • Expertise

Rotating Right's multiphase transfer pump (MTP) is a duplex, double-acting piston pump that is capable of handling up to 250,000 BOEPD of water, oil and gas mixtures. Our pump can handle up to 99.5% Gas Volume Fraction (GVF) continuously, and up to 100% gas on an intermittent basis. This pump can be designed up to 700 PSI differential pressure and up to 1,440 PSIG working pressure. With our design, the pump operates at a very low speed (less than 15 RPM) and can handle solids, high temperatures and high amounts of H<sub>2</sub>S. Our housing, pistons and liners can be made from a variety of materials to suit your pumping application. Our shaft sealing is a very simple design that is used on thousands of critical wells throughout the world.

seepex Multiphase Progressive Cavity Pumps can be run continuously in applications up to 99% GVF. Seepex is one of the world's leading progressive cavity pump manufacturers and has many years of experience in the design and manufacturing of progressive cavity pumps with the capabilities and expertise to design a system for your specific application.



# Rotating Right Certifications

**QMS**

**ISO 9001 : 2000  
REGISTERED FIRM**

## Certificate of Registration

This is to certify that the Quality Management Systems of

**ROTATING RIGHT INC.**

Has been assessed and approved by Quality Management Systems Canada Ltd. against the following quality assurance management system standard:

**ISO 9001:2000**

The Quality Management System is applicable to

The distribution, fabrication and servicing of surface pumping and hydraulic lift equipment and spare parts to the Oil, Gas and other industries. The construction, repair and alteration of ASME B31.1 power piping and ASME B31.3 process piping.

The approval is subject to the company maintaining its system to the required standards, which will be monitored by Quality Management Systems Canada Ltd.

Certificate Number: **AB 1449**

Date of Original Issue: **January 22, 2008**

Current Certificate: **January 22, 2008**

Current Expiry: **January 22, 2009**



For and on behalf of QMS

This certificate remains the property of QMS Quality Management Systems Canada Ltd. at all times. Lack of fulfillment of conditions as set forth in the QMS Certification Regulations or Contract may render this certificate invalid. This is not a legal document and cannot be used as such.

**Alberta**  
MUNICIPAL AFFAIRS

**ABSA**  
the pressure equipment safety authority

## Certificate of Authorization Quality Management System

Expiry Date: **March 17, 2009**

Reg. No.: **AQP-21228**

This is to certify that:

**ROTATING RIGHT INC.**  
6120 DAVIES ROAD  
EDMONTON, ALBERTA

having complied with the provisions of the SAFETY CODES ACT, is hereby authorized to:

**Construct, Repair/Alter ASME B31.1 Power Piping and ASME B31.3 Process Piping**

at the SHOP and FIELD sites controlled from the above address.



Form No. AB-121  
Rev. (2004/06)

Dated at Edmonton, this 3rd day of April, 2006



Chief Inspector and Administrator

Certificate No.: **4935**



**CERTIFICATE  
OF  
RECOGNITION**

This certificate recognizes that  
**ROTATING RIGHT INC.**

In keeping with the principles of *Partnerships* has:

- developed and implemented a workplace health and safety management system and,
- met the standard for *Partnerships* through an independent evaluation of their health and safety system.

  
Cindy Scholt  
Alberta Safety Council  
Partner in Health and Safety

Certificate # 20080220-7401  
WCB Industry Code(s): 62303

  
Joe Childs  
Director, Workplace Partnerships

Expiry Date: February 20, 2011

**Alberta**  
Employment, Immigration  
and Industry

## Accessories

Rotating Right offers a full line of accessories to ensure long trouble free and safe operation of your multiplex pumps.

### Accessories Include:

- Pulsation Dampeners - Suction & Discharge
- Vibration Shock Switches
- Liquid Level Gauges & Switches
- Pressure Safety Valves
- Plunger Lubricators
- Fire Safety Valves
- High Discharge Pressure Switch
- Condensate Drain
- N.A.C.E. Valving
- Lubricator Level Controller
- API Valves
- Drive Options



## Expendables



With our worldwide buying power Rotating Right is well equipped to provide a wide range of replacement parts & expendables for virtually all multiplex plunger pumps regardless of make or model.

Our expendables inventory includes plungers, packing, brass, valves, bearings, crankshafts, connecting rods and seals.



## Repair & Overhauls

Rotating Right service technicians follow strict quality control procedures for every pump repair and overhaul. The use of consistent and reliable re-manufacturing techniques ensure your equipment is returned to you in "Like New" condition.

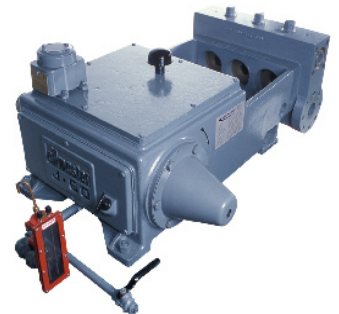

**Head Office:**  
6120 Davies Road  
Edmonton, AB  
T6E 4M9

Phone: (780) 485-2010 • Toll Free: (866) 707-7867  
Fax: (780) 485-1938  
• Calgary • Drayton Valley • Lethbridge  
[www.rotatingright.com](http://www.rotatingright.com)