

ROTATING RIGHT

# FLUID KINETICS AFC HYDRAULIC ACOUSTIC FILTER

FLUID KINETICS

## MODEL AFC HYDRAULIC ACOUSTIC FILTER

An inline device to minimize noise and pulsation  
generated by high speed, multiplunger pumps

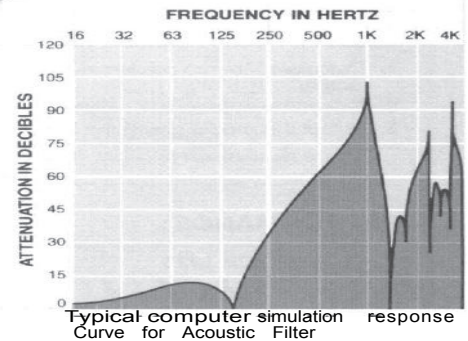
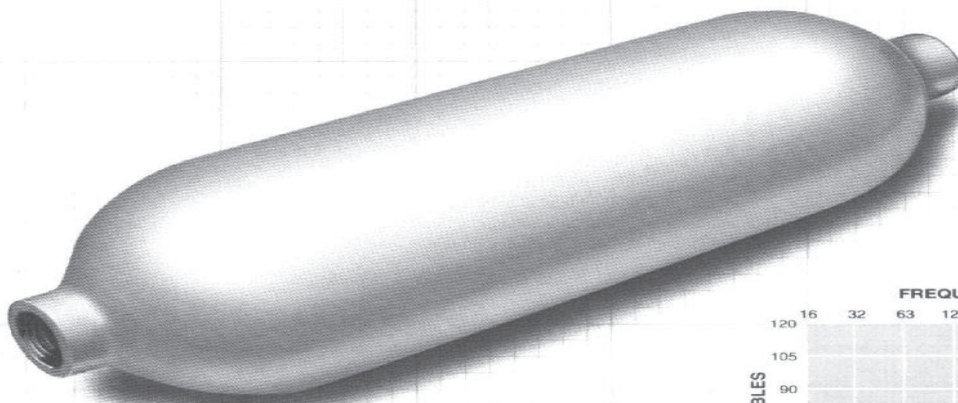

The Fluid Kinetics Hydraulic Acoustic Filter is designed to reduce by 15 to 20 dB noise and pulsation emanating from high speed hydraulic pumps. It offers a simple maintenance-free way to meet existing OSHA workplace standards for hydraulic systems in machine tool, hydraulic press, forging and test stand applications.

Typically, the Hydraulic Acoustic Filter is installed at the outlet of multi- (7 or more) piston, vane or gear type pumps in hydraulic systems. It is designed to block fluid-borne noise and pulsation from entering the connected piping. To prevent noise radiation from the pump and motor casing, a commercially available acoustic shroud should be used. This combination treatment is necessary only if there is a requirement to quiet the immediate environment of the hydraulic package. The Hydraulic Acoustic Filter effectively reduces all downstream piping noise.

### DESIGN

The multichambered acoustic filter acts analogously to an electrical filter network. It is designed to filter or attenuate the predominate frequency and significant harmonics of the pump.

This reactive type of filter does not require resistance or pressure drop to function. However, since there is flow through the filter some pressure drop is imposed. Filter overall size is an inverse function of pressure drop. A computer simulation response curve allows Fluid Kinetics engineers to check the selected AFC performance for each application.

### CONSTRUCTION

The Hydraulic Acoustic Filter is of all carbon steel construction with no bladder to fill or replace. Working pressures up to 5000 psig are standard. Higher pressures and stainless steel materials are available upon request.

### APPLICATION DATA

Use the selection charts for standard hydraulic system applications. For custom selection, give Fluid Kinetics the following data: pump speed range, pump type, fluid type, pressure, temperature, flow rate range, allowable pressure drop, connection size and type, and a brief description of piping downstream of pump to nearest large vessel (particle filter or accumulator).

**TYPICAL DETAIL:**

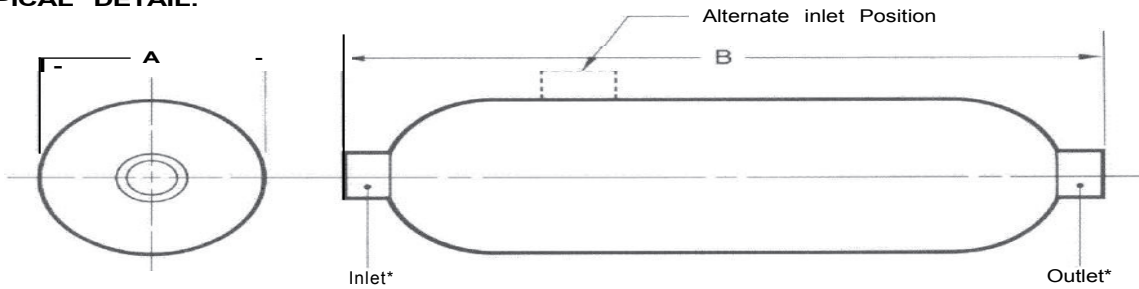

MODEL	A	B	SERIES 1325		SERIES 3000		SERIES 5000	
			MWP-PSI	WGT.-LBS.	MWP-PSI	WGT.- LBS.	MWP-PSI	WGT.- LBS.
AFC 40	4 1/2"	15"	1325	18	3000	34	5000	46
AFC 50	5 9/16"	18"	1325	31	3000	57	5000	75
AFC 60	6 3/8"	21"	1325	45	3000	87	5000	119
AFC 80	8 5/8"	24"	1325	85	3000	186	5000	200

\*Connections are NPT female thread. size to match pump connection

**SELECTION:**

Based on typical hydraulic fluid of 30 centistokes viscosity and .85 specific gravity.

1. Calculate "pump predominate frequency: if greater than 140 Hz, selection is appropriate. If less than, refer to factory.
2. Select the appropriate series for given working pressure.
3. Select the model giving the approximate allowable pressure drop.

\*\*Pump Predominate Frequency number of (pistons)(vanes)(teeth)xRPM/60

**PERFORMANCE:**

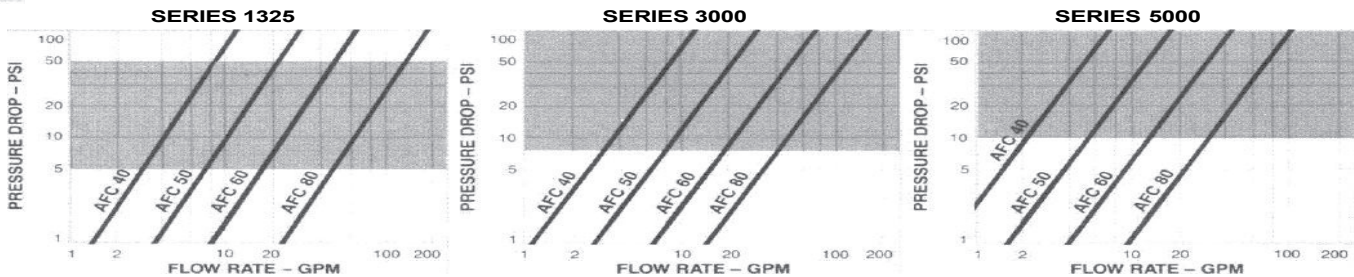

**Head Office:**  
 6120 Davies Road  
 Edmonton, AB  
 T6E 4M9

Phone: (780) 485-2010 • Toll Free: (866) 707-7867  
 Fax: (780) 485-1938  
 • Calgary • Drayton Valley • Lethbridge  
[www.rotatingright.com](http://www.rotatingright.com)